

# MotorGuide REPAIR PARTS

Model: **POWER plus**  
**T47**

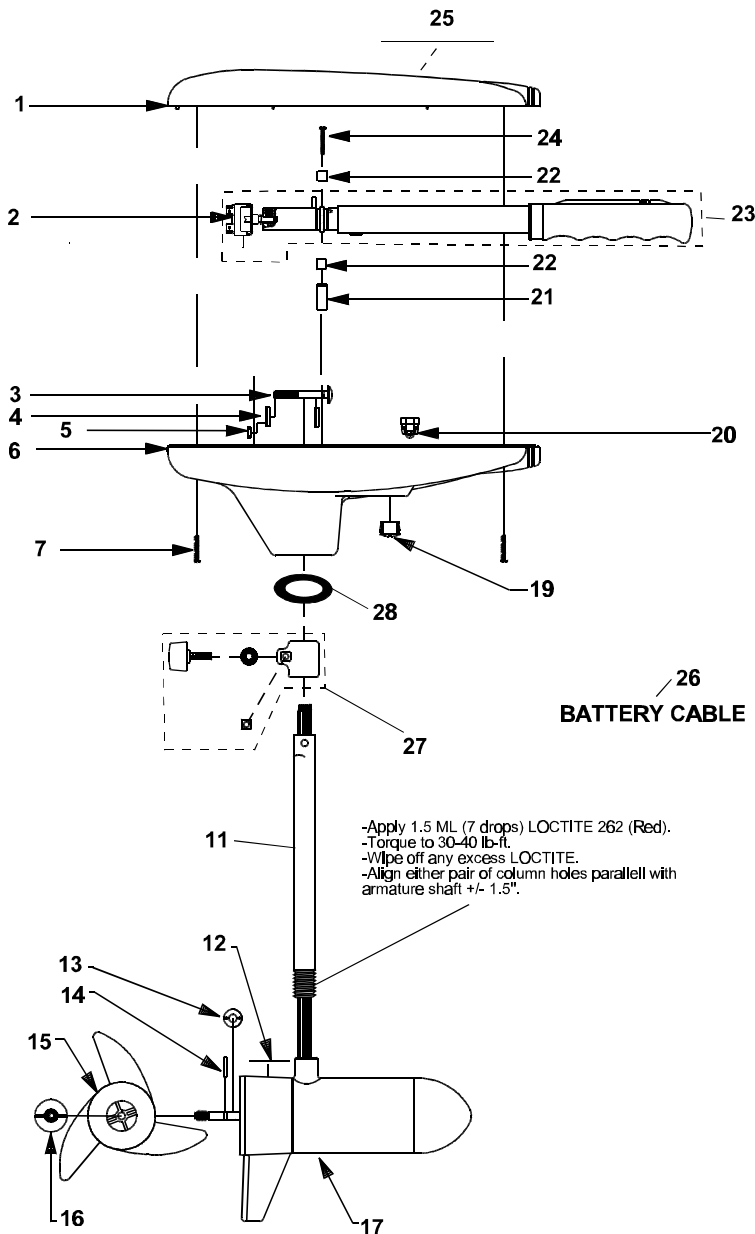

**SPECIFICATIONS:**

Year of Intro 1998  
 Thrust 47LBS  
 Volts 12VDC  
 Amp Draw 0 to 48 amps  
 Mount 03 Transom  
 Speeds 5/2

**QUICK REFERENCE PARTS GUIDE:**

Handle Asy BT372-06  
 Motor Seal Kit 6220  
 Rotary Switch KT150-02

**PARTS ORDERING & TECH ASSISTANCE**

MotorGuide Consumer Relations  
 Phone 918-831-6989  
 Fax 800-982-8093

**Send Returned Goods to:**  
 MotorGuide  
 605 Hwy 12 West  
 Starkville, MS 39760

*Returned Goods must be accompanied with a Returned Goods Authorization. Contact MotorGuide Consumer Relations to obtain RGA.*

KEY	DESCRIPTION	PART #	KEY	DESCRIPTION	PART #
1	COVER BLACK	AT053-18	28	COLUMN SEAL	AT079-01
2	ROTARY SWITCH	KT150-02			
3	BOLT	TT134-01			
4	CURVED WASHER	TT171-04			
5	NYLON LOCK NUT	XT098-02			
6	T/H BASE BLACK	AR004-14			
7	SCREW #8 X 1"	LF141-04			
8	BAR KNOB	AR082-02			
9	CLAMP WASHER	AR171-01			
10	SUPPORT NUT	FR098-01			
11	42" .095 SS H/O COLUMN	FR049-15			
12	MARINE LOWER UNIT DECAL	AF060-04			
13	MONOFILAMENT WASHER	AR175-01			
14	PROP DRIVE PIN	BR102-01			
15	PROP/ 3 BLADE	AF124-10			
16	PROP NUT	AR099-01			
17	MOTOR	DF397-02			
18	DEPTH ADJUSTMENT COLLAR	AR051-01			
19	1/2" HOLE PLUG	FP021-03			
20	GROMMET	GR019-03			
21	WIRE BRACKET	AT155-04			
22	RETAINER CLAMP	AR036-01			
23	5 SPEED HANDLE ASY 96-97	BT372-06			
24	8 X 1-3/8 SCREW	AR133-01			
25	NOMENCLATURE	FT056-13			
26	BATTERY CABLE	TT328-03			
27	DEPTH COLLAR ASY	AR158-01			

LOWER UNIT BREAKDOWN

Model:  
**T47**

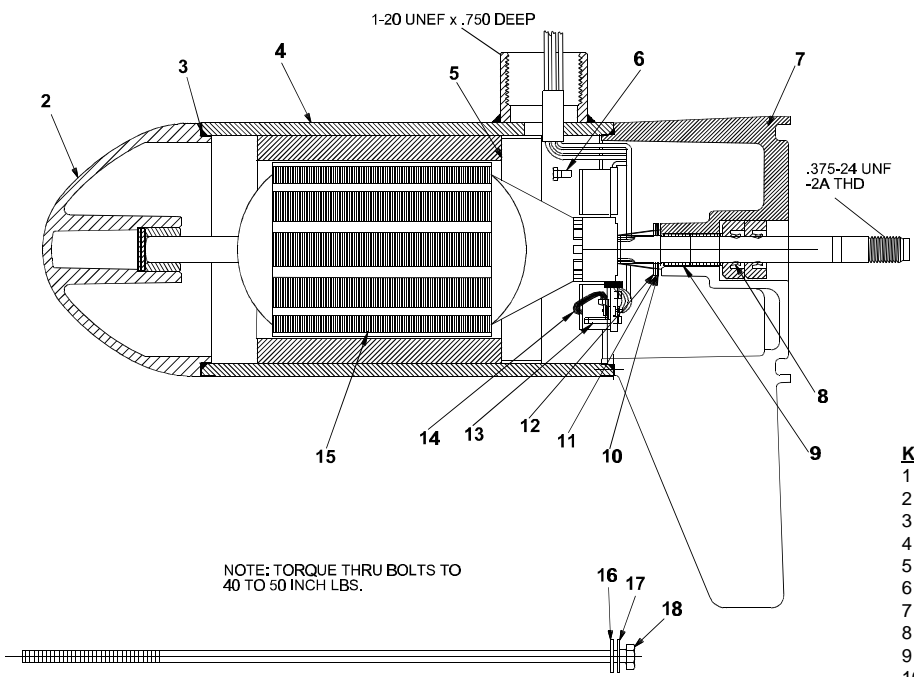

KEY	QTY	DESCRIPTION	PART NO.
1	X	MOTOR	DF397-02
2	1	NOSE CAP	JF3212-01
3	2	O RING SEAL	MR217-01
4	1	HOUSING ASY	JF3210-01
5	1	RETAINER	JF233-01
6	2	BRUSH CARD SCREW	MR228-01
7	1	COMM CAP	DF3205-01
8	2	SHAFT SEAL	MR223-01
9	1	BEARING	MR206-01
10	1	NYLATRON WASHER	MR226-01
11	1	WASHER	MR227-01
12	1	E RING	MR219-01
13	2	BRUSH SPRINGS	MR214-02
14	1	BRUSH ASY LESS SPRING	DF3201-01
15	1	ARMATURE 3.5"	CF3207-02
16	4	STATIC SEAL	MR222-01
17	4	THRU BOLT WASHER	MR216-01
18	2	THRU BOLT	MR218-02

WIRING

